

MANNY

W O R K B E N C H

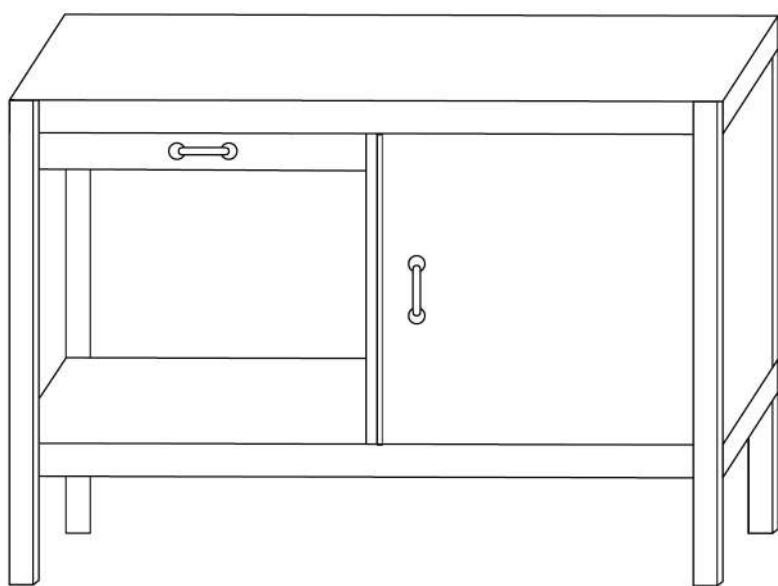

IT

FR

UK

ES

BOUDECH

SPECIFICHE TECNICHE

TECHNICAL SPECIFICATIONS/ SPÉCIFICATIONS TECHNIQUES/ ESPECIFICACIONES TÉCNICAS

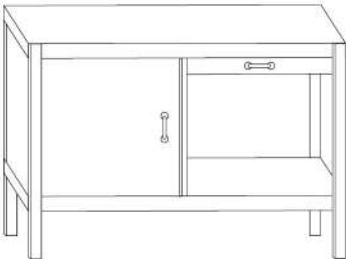
	Overview	IT-UK-ES-FR
		<p>Questa stazione da lavoro è l'ideale per chi ama il fai da te e necessita di una piccola officina portatile per effettuare i suoi lavori e riporre gli utensili in modo ordinato ed in vista così da non dover più perder tempo a cercarli in giro.</p>
		<p>This workstation is ideal for those who love to do their own work and need a small portable workshop to carry out their work and store the tools in an orderly manner and in sight so that you no longer have to waste time looking around.</p>
		<p>Esta estación de trabajo es ideal para los aficionados al bricolaje que necesitan un pequeño taller portátil para realizar sus trabajos y guardar las herramientas de forma ordenada y a la vista, para no tener que perder tiempo buscando por ahí.</p>
		<p>Ce poste de travail est idéal pour ceux qui aiment le bricolage et ont besoin d'un petit atelier portable pour effectuer leurs travaux et stocker les outils de manière ordonnée et en vue afin de ne pas perdre plus de temps à chercher autour.</p>

SICUREZZA



Leggere attentamente le istruzioni prima di utilizzare l'attrezzo.

1. Indossare occhiali di sicurezza e guanti da lavoro pesanti durante il montaggio.
2. Mantenere l'area di assemblaggio pulita e ben illuminata.
3. Tenere gli astanti fuori dalla zona durante il montaggio.
4. Non montare quando siete stanchi o sotto l'influenza di alcol, droghe o farmaci.
5. La capacità di peso e le altre capacità del prodotto si applicano solo al prodotto correttamente e completamente assemblato.
6. Questo prodotto non è un giocattolo. Non permettere ai bambini di giocare con o vicino a questo articolo.
7. Installare e utilizzare solo al chiuso. Mantenere asciutto.
8. Non stringere eccessivamente il pezzo da montare; potrebbero verificarsi danni al pezzo. Fare attenzione a non schiacciare le dita durante il lavoro.
9. Posizionare il banco da lavoro su una superficie piana, livellata e solida che sia in grado di sostenere il peso del banco da lavoro e degli strumenti.
10. Usare solo come previsto.
11. Attenzione! La difficoltà di montaggio per questo attrezzo è medio-alta, se possibile, farsi aiutare nel assemblare le varie componenti.
12. Nel caso in cui parti o componenti siano usurati e/o danneggiati rivolgersi a franchinishop.com per la ricambistica originale.

SAFETY



Leggere attentamente le istruzioni prima di utilizzare l'attrezzo.

1. Wear heavy safety goggles and work gloves when mounting.
2. Keep the assembly area clean and well lit.
3. Keep bystanders out of the area during editing.
4. Do not ride when you are tired or under the influence of alcohol, drugs or medications.
5. The weight capacity and other product capacities apply only to the properly assembled product.
6. This product is not a toy. Do not allow children to play with or near this item.
7. Install and use only indoors. Keep dry.
8. Do not over-tighten the part to be mounted; damage to the part may occur. Be careful not to crush your fingers while working.
9. Place the workbench on a flat, level and solid surface that can support the weight of the workbench and tools.
10. Use only as intended.
11. Attention! The difficulty of assembly for this tool is medium-high, if possible, get help in assembling the various components.
12. In case of worn and/or damaged parts, contact franchinishop.com for the original spare parts.

SEGURIDAD



Lea atentamente las instrucciones antes de utilizar la herramienta.

1. Use gafas de seguridad y guantes de trabajo pesados durante el montaje.
2. Mantenga el área de montaje limpia y bien iluminada.
3. Mantenga a los espectadores fuera de la zona durante el montaje.
4. No lo monten cuando estén cansados o bajo la influencia de alcohol, drogas o medicamentos.
5. La capacidad de peso y otras capacidades del producto solo se aplican al producto correctamente y completamente ensamblado.
6. Este producto no es un juguete. No permita que los niños jueguen con o cerca de este artículo.
7. Instalar y utilizar solo en interiores. Mantener seco.
8. No apriete demasiado la pieza de trabajo; puede dañarse. Tenga cuidado de no aplastar los dedos durante el trabajo.
9. Coloque el banco de trabajo sobre una superficie plana, nivelada y sólida que pueda soportar el peso del banco de trabajo y las herramientas.
10. Utilizar solo como se ha previsto.
11. Atención! La dificultad de montaje para esta herramienta es media-alta, si es posible, obtener ayuda para ensamblar los diferentes componentes.
12. En caso de que las piezas o componentes se desgasten y/ o dañados, póngase en contacto con franchinishop.com para obtener repuestos originales.

S É C U R I T É



Lire attentivement les instructions avant d'utiliser l'outil.

1. Porter des lunettes de sécurité lourdes et des gants de travail lors du montage.
2. Gardez la zone de montage propre et bien éclairée.
3. Gardez les spectateurs hors de la zone pendant le montage.
4. Ne pas rouler lorsque vous êtes fatigué ou sous l'influence de l'alcool, des drogues ou des médicaments.
5. La capacité de poids et les autres capacités du produit ne s'appliquent qu'au produit correctement assemblé.
6. Ce produit n'est pas un jouet. Ne laissez pas les enfants jouer avec ou près de cet article.
7. Installer et utiliser uniquement à l'intérieur. Garder au sec.
8. Ne serrez pas trop la pièce à monter, car elle pourrait être endommagée. Veillez à ne pas vous écraser les doigts pendant le travail.
9. Placez l'établi sur une surface plane, plane et solide qui peut supporter le poids de l'établi et des outils.
10. Utiliser uniquement comme prévu.
11. Attention! La difficulté de montage pour cet outil est moyenne-haute, si possible, obtenir de l'aide dans le montage des différents composants.
12. En cas de pièces usées et/ou endommagées, contacter franchinishop.com pour les pièces de rechange d'origine.

DIAGRAMMA DELLE PARTI

N°	DESCRIZIONE	Qty
1	Staffa sinistra sul piede posteriore	1
2	Staffa proprio sul piede posteriore	1
3	Piede anteriore sinistro	1
4	Piede anteriore destro	1
5	Staffa lunga con foro di collegamento centrale	1
6	Staffa lunga	2
7	Staffa breve	4
8	Staffa lunga con foro di collegamento centrale	1
9	Staffa lunga	1
10	Pannello di sinistra	1
11	Pannello destro assemblato	1
12	Pannello posteriore	1
13	La porta	1
14	Staffa di connessione centrale	3

N°	DESCRIZIONE	Qty
15	Staffa sinistra	1
16	Staffa destra	1
17	Binari	2
18	Pannello laterale	1
19	Frontale del cassetto	1
20	Pannello posteriore del cassetto	1
21	Cassettiera 515×445	1
22	Pannello sottobanco 595×585	1
23	Pannello portaoggetti 600×575	2
24	Piano di lavoro 1195×592×9	1
25	Maniglie	2
26	Serratura	1
27	Viti M6×10 a croce a maglia circolare	72
28	Dado M6	72
29	Vite a croce base piatta M4×10	8
30	Dado M4	8

DIAGRAM OF THE PARTS

N°	Description	Qty
1	Left bracket on rear foot	1
2	Bracket right on the rear foot	1
3	Left front foot	1
4	Right front foot	1
5	Long bracket with central connection hole	1
6	Long bracket	2
7	Short term	4
8	Long bracket with central connection hole	1
9	Long bracket	1
10	Left panel	1
11	Right panel assembled	1
12	Rear panel	1
13	The door	1
14	Central connection bracket	3

N°	Description	Qty
15	Left side bracket	1
16	Right bracket	1
17	Tracks	2
18	Side panel	1
19	Drawer front	1
20	Drawer back panel	1
21	Chest of drawers 515 445	1
22	Under-bench panel 595 585	1
23	Storage panel 600 575	2
24	Work plan 1195 592 9	1
25	Handles	2
26	Lock	1
27	Screws M6 10 to cross circular mesh	72
28	Nut M6	72
29	Flat-base cross screw M4 10	8
30	Nut M4	8

DIAGRAMA DE LAS PARTES

Nº	Descripción	Qty
1	Soporte izquierdo en el pie trasero	1
2	Soporte justo en el pie trasero	1
3	Pie delantero izquierdo	1
4	Pie delantero derecho	1
5	Soporte largo con agujero de conexión central	1
6	Soporte largo	2
7	Breve paso	4
8	Soporte largo con agujero de conexión central	1
9	Soporte largo	1
10	Panel de la izquierda	1
11	Panel derecho ensamblado	1
12	Panel trasero	1
13	La puerta	1
14	Soporte de conexión central	3







N°	Descripción	Qty
15	Soporte izquierdo	1
16	Soporte derecho	1
17	Vías	2
18	Panel lateral	1
19	Frente del cajón	1
20	Panel trasero del cajón	1
21	Cajonera 515 445	1
22	Panel bajo el banco 595 585	1
23	Panel de almacenamiento 600 575	2
24	Plan de trabajo 1195 592 9	1
25	Manijas	2
26	Cerradura	1
27	Tornillos M6 10 de malla circular	72
28	Tuerca M6	72
29	Tornillo de cruz plana M4 10	8
30	Tuerca M4	8



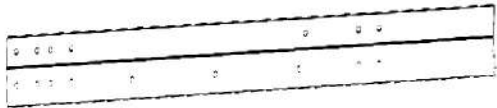

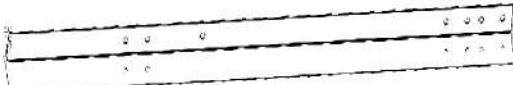
SCHÉMA DES PARTIES



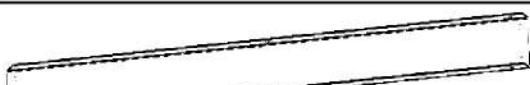

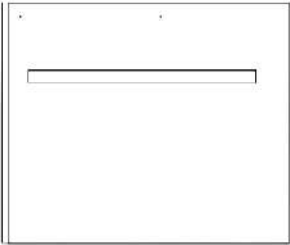
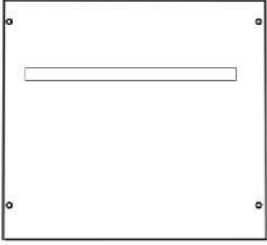

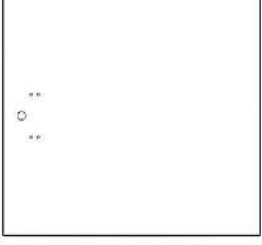
N°	Description	Qty
1	Support gauche sur le pied arrière	1
2	Support situé sur le pied arrière	1
3	Pied avant gauche	1
4	Pied droit avant	1
5	Support long avec trou de connexion central	1
6	Support long	2
7	À court terme	4
8	Support long avec trou de connexion central	1
9	Support long	1
10	Panneau de gauche	1
11	Panneau droit assemblé	1
12	Panneau arrière	1
13	La porte	1
14	Support de connexion central	3



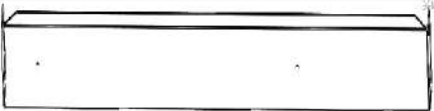

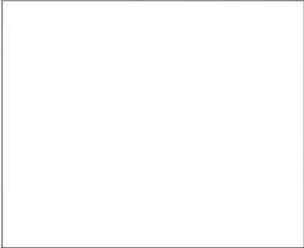

N°	Description	Qty
15	Support latéral gauche	1
16	Parenthèse droite	1
17	Pistes	2
18	Panneau latéral	1
19	Tiroir avant	1
20	Panneau arrière du tiroir	1
21	Commode 515 445	1
22	Panneau sous banc 595 585	1
23	Panneau de stockage 600 575	2
24	Plan de travail 1195 592 9	1
25	Poignées	2
26	Lock	1
27	Vis M6 10 pour croiser le filet circulaire	72
28	Écrou M6	72
29	Vis à base plate M4 10	8
30	Écrou M4	8

LISTA PARTI

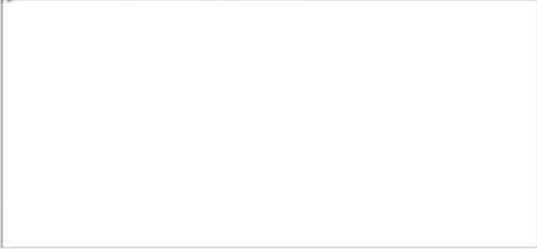
IMG	N°	QTY.
	1	1
	2	1
	3	1
	4	1
	5	1
	6	1
	7	4
	8	1
	9	1

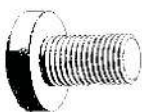
IMG	N°	QTY.
	10	1
	11	1
	12	1
	13	1
	14	3
	15	1

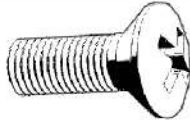
IMG	N°	QTY.
	16	1
	17	2
	18	1
	19	1
	20	3
	21	1
	22	1

IMG	N°	QTY.
	23	1
	24	1
	25	2
	26	1
	27	72
	28	72
	29	8
	30	8

MONTAGGIO

ASSEMBLY/ MONTAJE/ ASSEMBLAGE

① 27  × 8

28  × 8

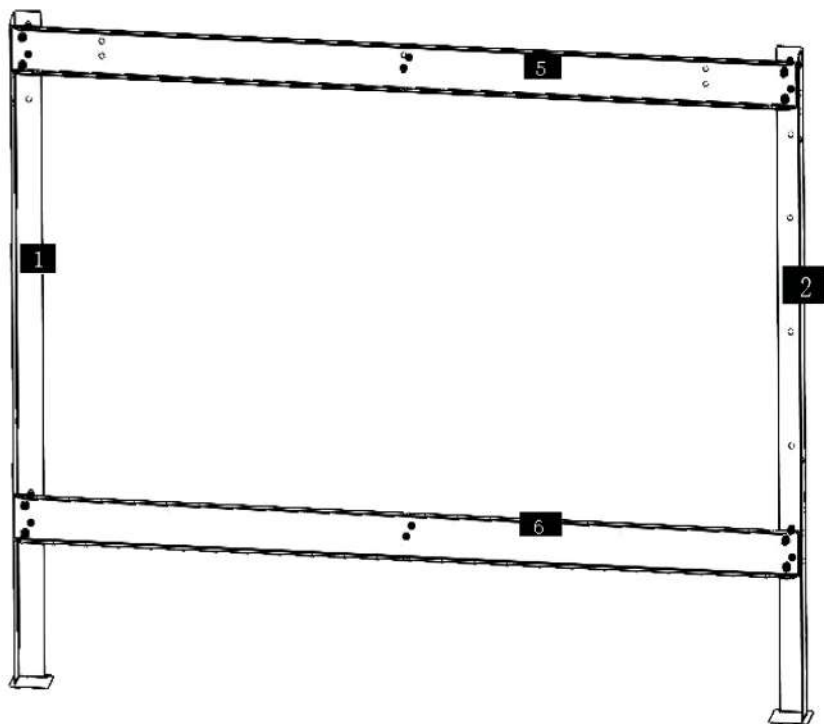

② 27



×8

28



×8

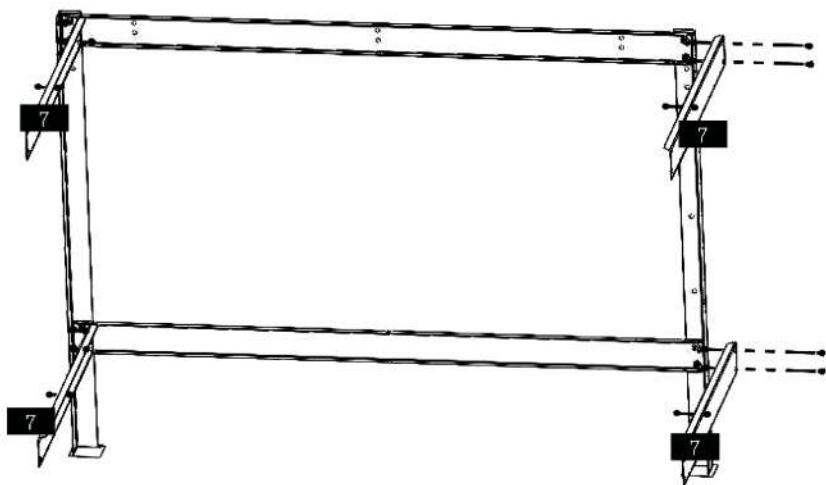

③ 27  × 16

28  × 16

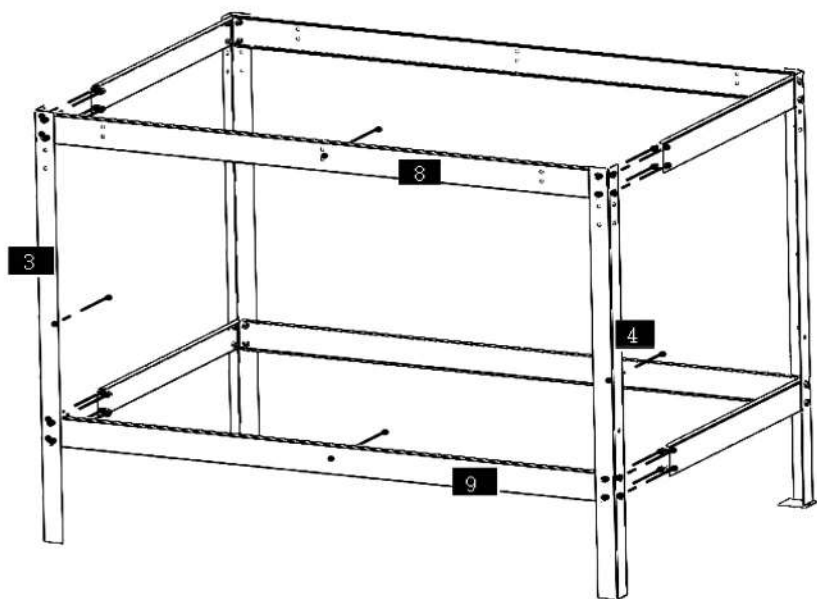

④

27



×4

28



×4

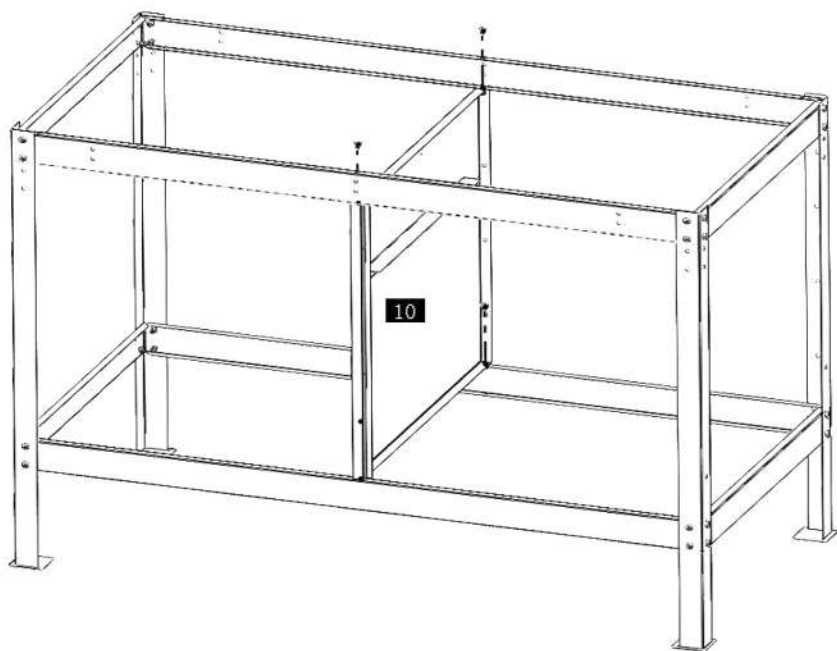

5

27



× 6

28



× 6

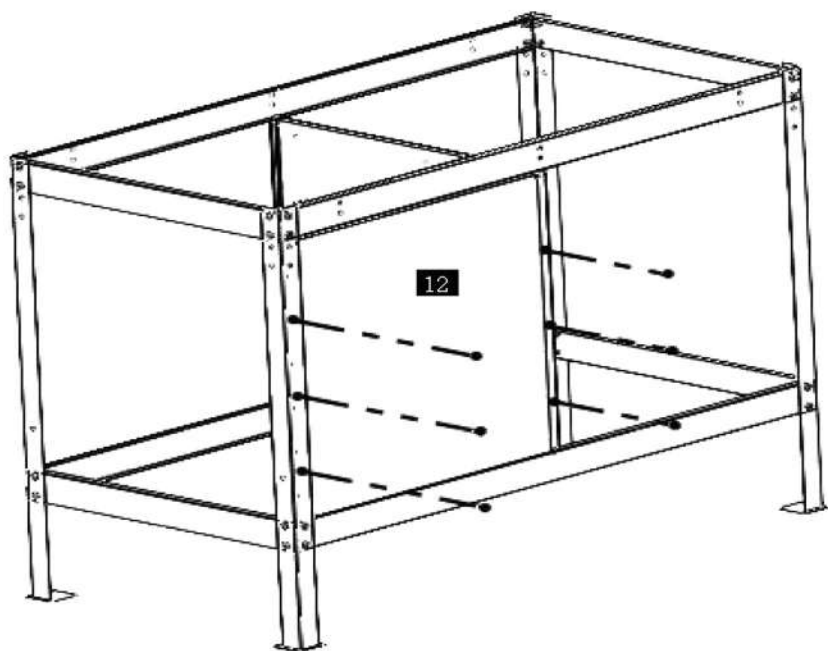

⑥

27



×4

28



×4

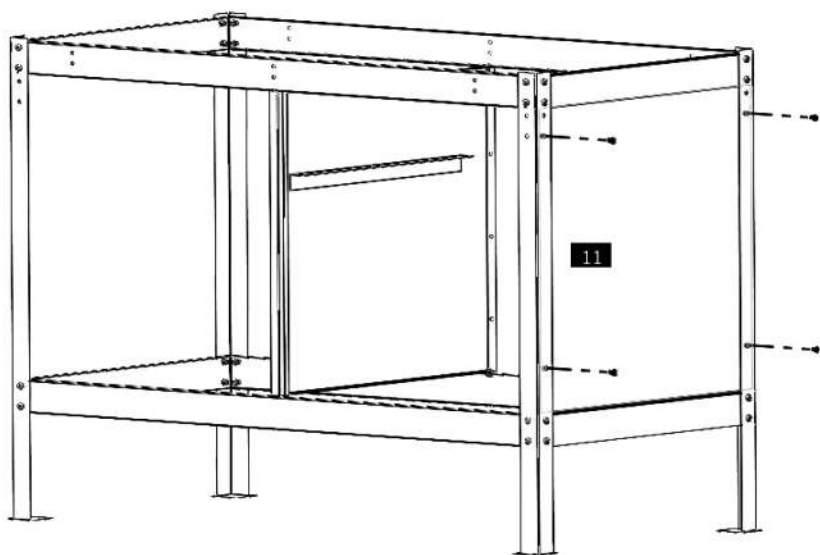

7

27



×2

28



×2

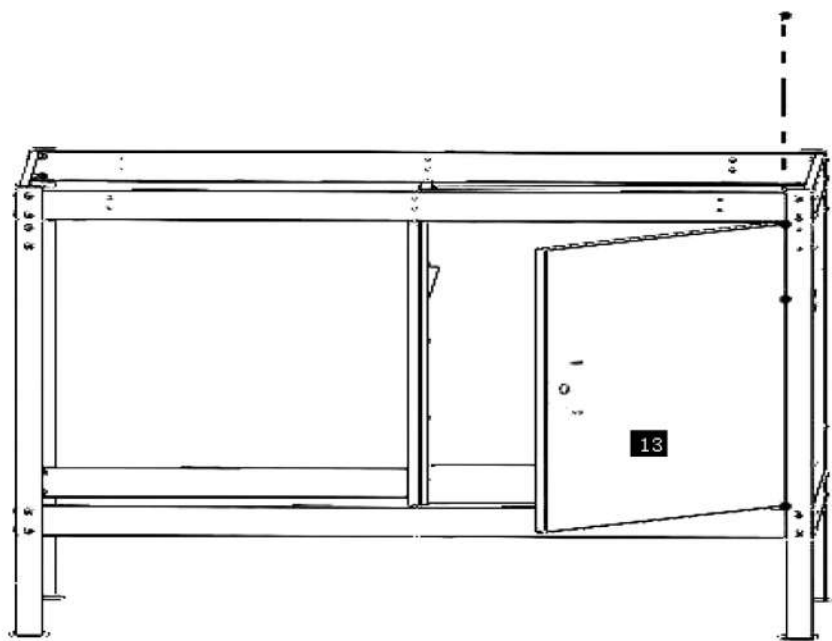

⑧

27



×12

28



×12

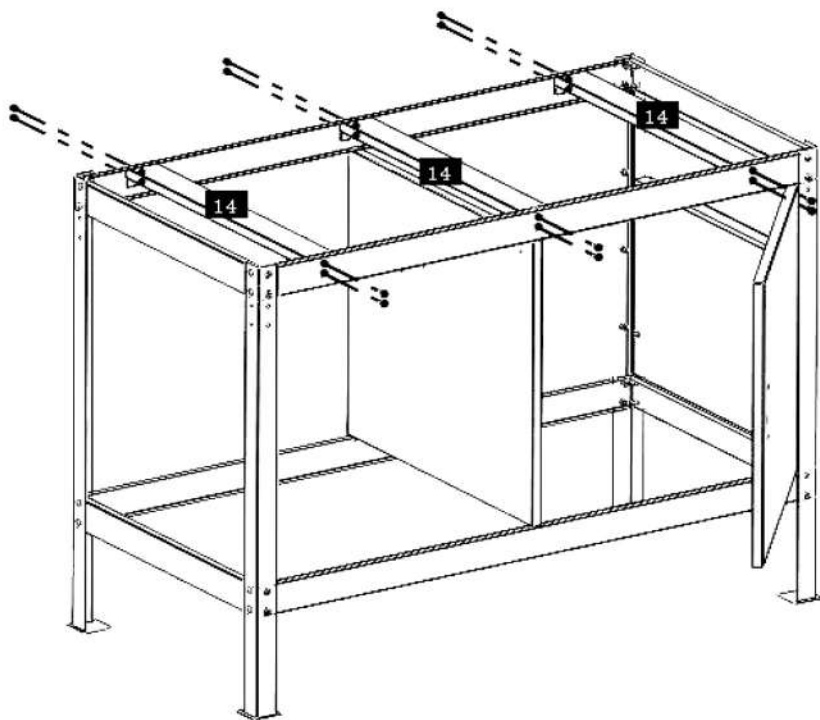

9

27



×4

28



×4

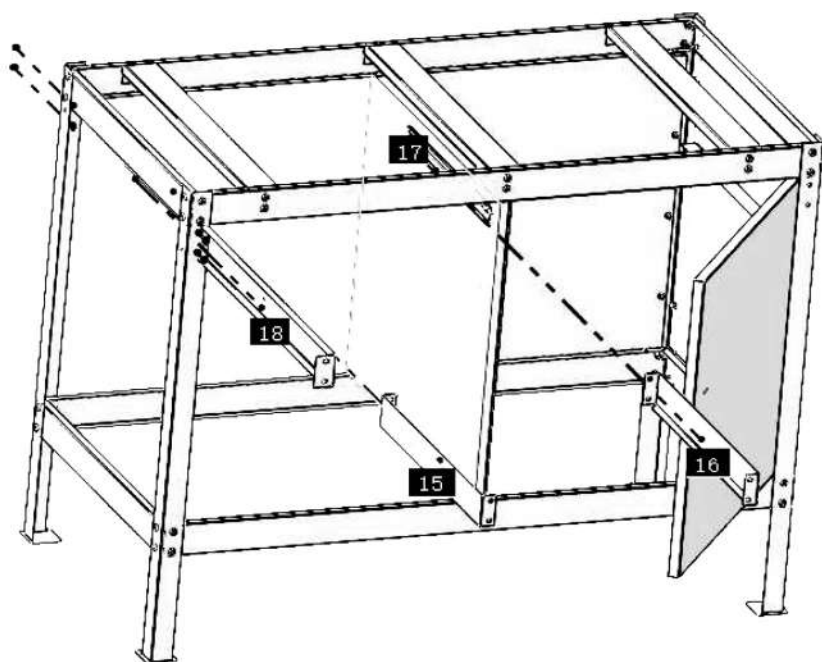

⑩

27



×8

28



×8

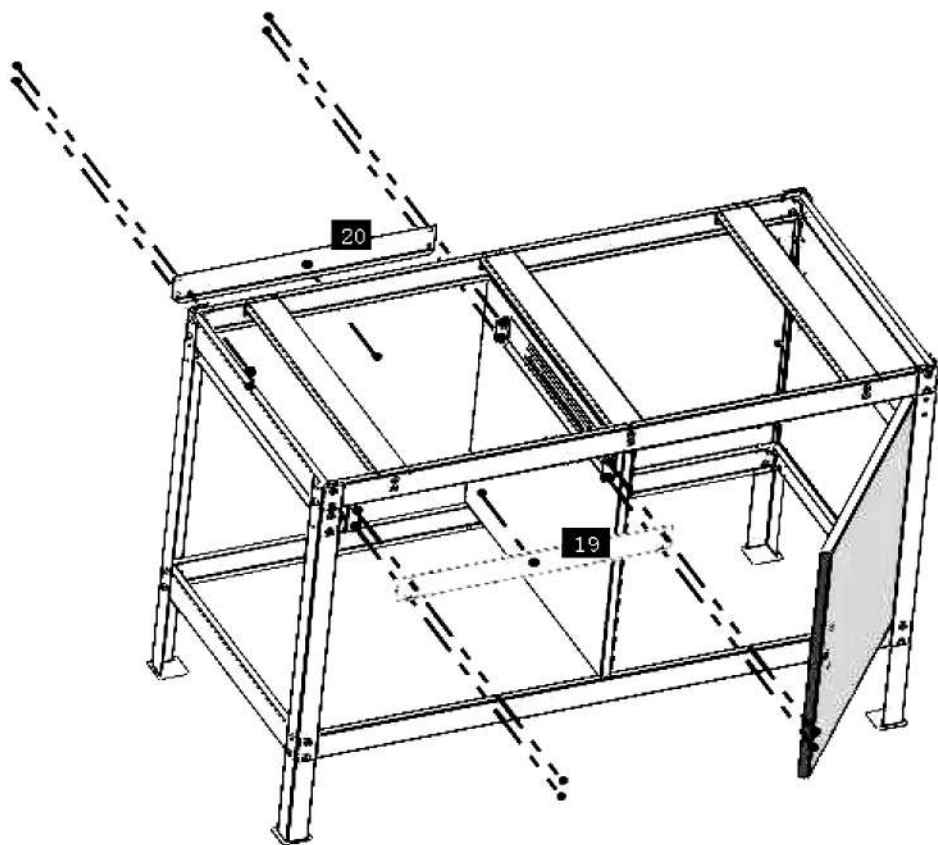

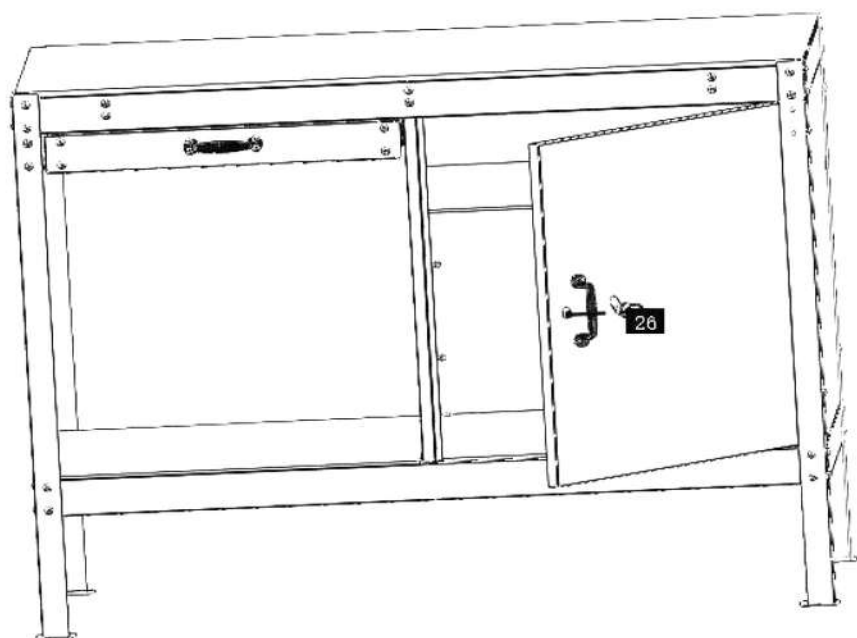

DISCOVER ALL OUR PRODUCTS ON
TOOLS.BOUDECH.COM

BOUDECH

EMPOWERING EQUIPMENTS

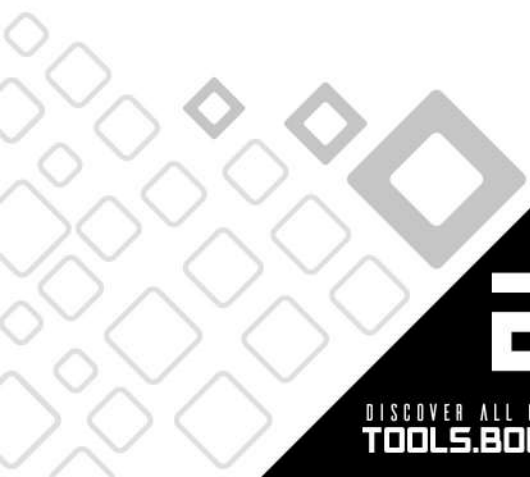

A large, bold, stylized letter 'B' logo. The 'B' is white with a thick black outline, set against a black triangular background that points upwards. The 'B' has a unique, blocky design with a horizontal bar that is slightly offset from the top and bottom strokes.

DISCOVER ALL OUR PRODUCTS ON
[TOOLS.BOUDECH.COM](https://tools.boudech.com)